



For Generations

McWANE



SIZES - 4" to 36"

TR FLEX® RESTRAINED JOINT DUCTILE IRON
PIPE AND FITTINGS



For Generations

4" - 36" DUCTILE IRON TR FLEX[®] PIPE

MATERIAL	Ductile Iron per AWWA C150/ANSI A21.50, AWWA C151/ANSI A21.51, ASTM A536
PRESSURE	350 PSI Water Working Pressure 4" - 24" & 250PSI FOR 30 & 36"
TESTING	ANSI / AWWA C151 / ANSI 21.51 & UL - FM requirements
LAYING LENGTH	18 foot Nominal Length
CEMENT LINING	ANSI / AWWA C104 / ANSI 21.4
COATING	ANSI / AWWA C104 / ANSI 21.4
GASKETS	ANSI / AWWA C111/ ANSI A21.11
STANDARDS	AWWA C150/ANSI A21.50, AWWA C151/ANSI A21.51, AWWA C104 / ANSI 21.4, AWWA C111/ ANSI A21.11



4"-20"



24"-36"

❖ visit pe.mcwane.com for more information

❖ All Dimensions are in Inches

TR FLEX[®] RESTRAINED JOINT DUCTILE IRON PIPE AND FITTINGS



For Generations

DUCTILE IRON TR FLEX® Pulling Force at Equivalent Pressure for HDD Applications

Nominal Pipe Size	Pipe O.D. (in)	350 psi Equivalent Force	500 psi Equivalent Force	Recommended Maximum Pulling Force	Absolute Maximum Pulling Force
4	4.80	6,333	9,048	6,000	9,000
6	6.90	13,087	18,696	13,000	18,000
8	9.05	22,514	32,163	22,000	32,000
10	11.10	33,869	48,384	33,000	48,000
12	13.20	47,897	68,424	47,000	68,000
14	15.30	64,349	91,927	64,000	91,000
16	17.40	83,226	118,894	83,000	118,000
18	19.50	104,527	149,324	104,000	149,000
20	21.60	128,252	183,218	128,000	183,000
24	25.80	182,977	261,396	182,000	261,000
30	32.00	201,062	281,487	201,000	281,000
36	38.30	288,023	403,232	288,000	403,000

Notes:

- 350 psi is the rated pressure of the joint.
- 500 psi equivalent is the absolute maximum pulling force that should be used.
- 30" and 36" Equivalent Forces are 250 psi equivalent

Actual Laying Length

Nominal Size	Feet	Inch
4	18	1
6	18	1
8	18	1
10	17	11
12	17	11
14	17	10
16	17	10
18	17	10
20	17	9
24	17	9
30	17	9
36	17	7

❖ visit pe.mcwane.com for more information

❖ All Dimensions are in Inches



For Generations

DUCTILE IRON TR FLEX® PIPE 4" - 36" Bell Details

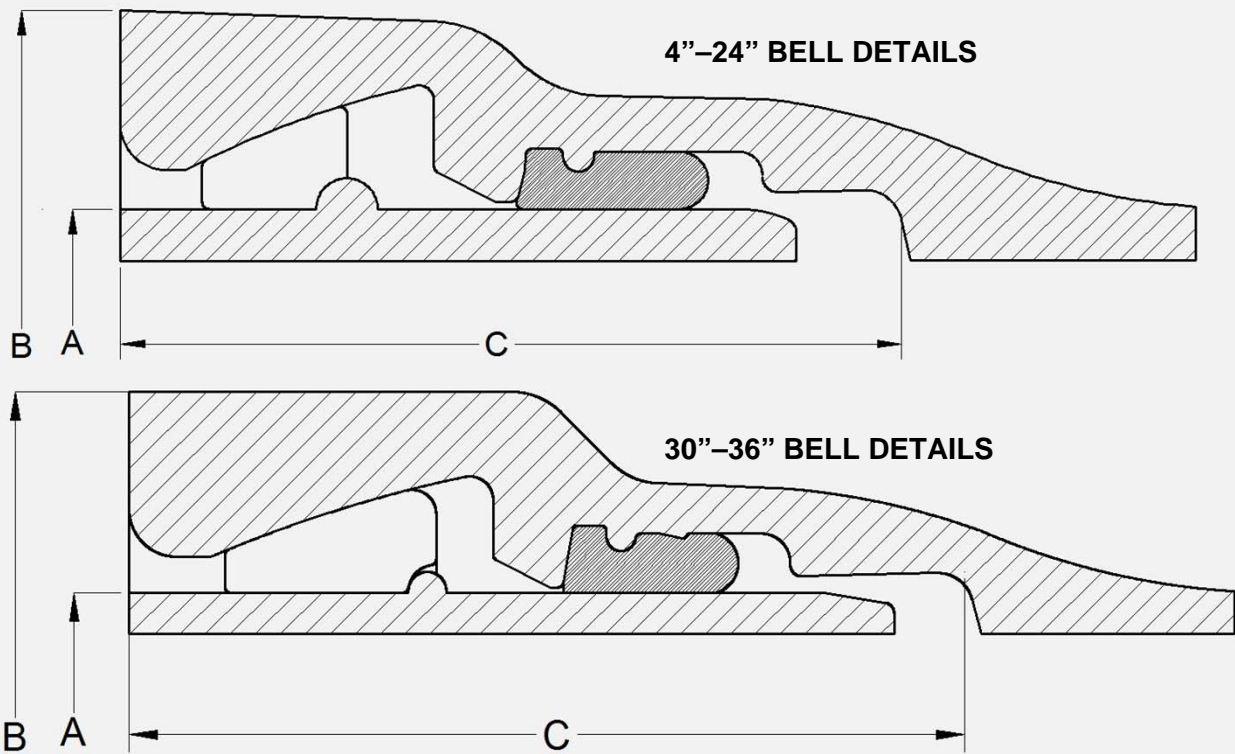

Pipe Size In.	*Pressure Rating psi	A	B	C	# of D.I Locking Segments	# of Rubber Segments Retainers	Max Deflection Degrees	Pullout
		In.	In.	In.				
4	350	4.80	7.25	4.84	2	1	5	0.03
6	350	6.90	9.52	5.27	2	1	5	0.04
8	350	9.05	11.93	5.82	2	1	5	0.04
10	350	11.10	14.37	6.03	2	1	5	0.05
12	350	13.20	16.68	6.30	4	2	5	0.06
14	350	15.30	19.16	7.75	4	2	3-1/4	0.05
16	350	17.40	21.46	7.95	4	2	3-1/4	0.05
18	350	19.50	23.76	8.19	4	2	3	0.05
20	350	21.60	26.04	8.40	4	2	2-1/2	0.05
24	350	25.80	30.61	8.86	8	4	2-1/4	0.05
30	250	32.00	36.88	10.28	8	4	1-3/4	0.05
36	250	38.30	43.85	10.87	8	4	1-1/2	0.05

*The TR FLEX® Restrained Joint has a working pressure rating equivalent to the working pressure rating of the parent pipe with a maximum working pressure rating of 350 psi for 4 in. through 24 in. and 250 psi for 30 in. through 36 in.

NOTE: These deflections are based on joints with nominal dimensions.

❖ visit pe.mcwane.com for more information

❖ All Dimensions are in Inches

TR FLEX® RESTRAINED JOINT DUCTILE IRON PIPE AND FITTINGS



For Generations

DUCTILE IRON TR FLEX® FITTINGS

MATERIAL	Ductile Iron Grade 70-50-05 in accordance with AWWA C153 / ANSI A21.53
PRESSURE	350 PSI Water Working Pressure for 4" - 24" & 250PSI for 30 & 36"
TESTING	AWWA C153 / ANSI A21.53 & UL - FM requirements
LAYING LENGTH	AWWA C153 / ANSI A21.53
CEMENT LINING	AWWA C104 / ANSI A21.4
COATING	AWWA C104 / ANSI A21.4
GASKETS	AWWA C111 / ANSI A21.11
STANDARDS	AWWA C153 / ANSI A21.53, AWWA C104 / ANSI A21.4, AWWA C111 / ANSI A21.11

BASIC SPECIFICATIONS

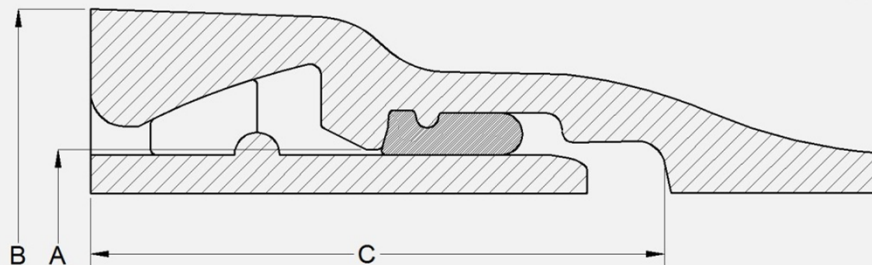

SIZE	A in	B in	C in
4	4.80	7.11	4.84
6	6.90	9.39	5.27
8	9.05	11.85	5.82
10	11.10	14.12	6.03
12	13.20	16.46	6.30
14	15.30	19.13	7.75
16	17.40	21.33	7.95
18	19.50	23.53	8.19
20	21.60	25.75	8.40
24	25.80	30.15	8.86
30	32.00	37.19	10.28
36	38.30	43.85	10.87

❖ visit pe.mcwane.com for more information

❖ All Dimensions are in Inches

TR FLEX® RESTRAINED JOINT DUCTILE IRON PIPE AND FITTINGS



For Generations

TR FLEX[®] FITTING THICKNESS & DIMENSIONS BENDS

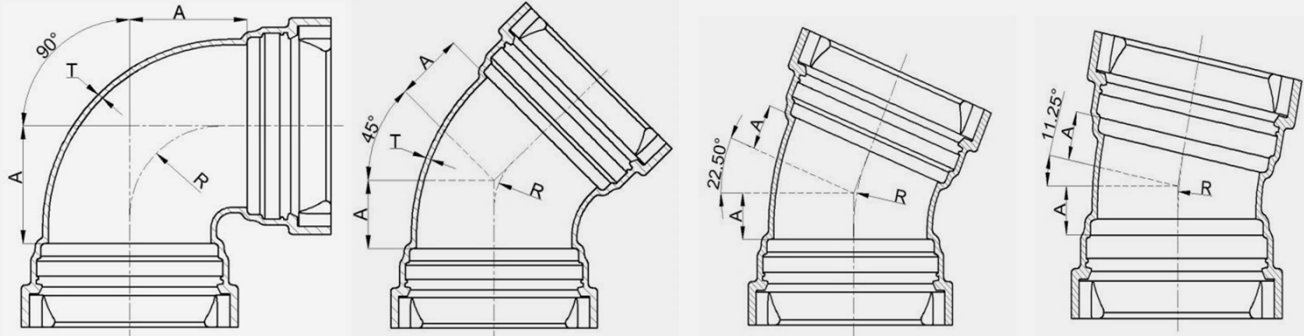

SIZE	90°			45°			22 1/2°			11 1/4°		
	A in	R in	T in	A in	R in	T in	A in	R in	T in	A in	R in	T in
4	4.00	3.34	0.34	2.00	3.24	0.34	1.50	4.23	0.34	1.25	6.01	0.34
6	5.00	4.31	0.36	3.00	5.57	0.36	2.00	6.57	0.36	1.50	8.19	0.36
8	6.50	5.60	0.38	3.50	6.28	0.38	2.50	8.04	0.38	1.75	8.62	0.38
10	7.50	6.68	0.40	4.50	8.89	0.40	3.00	10.97	0.40	2.00	12.00	0.40
12	9.00	7.76	0.42	5.50	11.00	0.42	3.50	13.50	0.42	2.25	14.50	0.42
14	11.50	10.00	0.47	5.00	8.50	0.47	3.75	12.00	0.47	2.50	11.00	0.47
16	12.50	11.00	0.50	5.50	9.50	0.50	3.75	11.50	0.50	2.50	10.00	0.50
18	14.00	12.50	0.54	6.00	10.50	0.54	4.50	14.50	0.54	3.00	14.00	0.54
20	15.00	13.50	0.57	7.00	13.00	0.57	4.50	14.00	0.57	3.00	13.00	0.57
24	16.75	15.00	0.61	7.50	14.00	0.61	4.50	14.00	0.61	3.00	13.50	0.61
30	21.50	19.00	0.66	10.50	20.50	0.66	6.75	24.00	0.66	4.75	29.00	0.66
36	24.50	22.00	0.74	11.50	22.50	0.74	7.75	28.00	0.74	5.00	30.00	0.74

❖ visit pe.mcwane.com for more information

❖ All Dimensions are in Inches

TR FLEX[®] RESTRAINED JOINT DUCTILE IRON PIPE AND FITTINGS

TR FLEX[®] FITTING THICKNESS & DIMENSIONS TEES

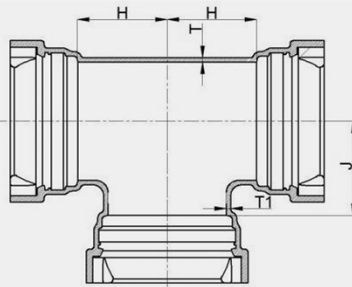

SIZE		H in	J in	T in	T1 in
Run	Branch				
4	4	4.00	4.00	0.34	0.34
6	4	4.00	5.00	0.36	0.34
6	6	5.00	5.00	0.36	0.36
8	4	4.00	6.50	0.38	0.34
8	6	5.00	6.50	0.38	0.36
8	8	6.50	6.50	0.38	0.38
10	4	4.00	7.50	0.40	0.34
10	6	5.00	7.50	0.40	0.36
10	8	6.50	7.50	0.40	0.38
10	10	7.50	7.50	0.40	0.40
12	4	4.00	8.75	0.42	0.34
12	6	5.00	8.75	0.42	0.36
12	8	6.50	8.75	0.42	0.38
12	10	7.50	8.75	0.42	0.40
12	12	8.75	8.75	0.42	0.42
14	14	10.50	10.50	0.47	0.47
16	12	9.50	11.50	0.50	0.42
16	14	10.50	11.50	0.50	0.47
16	16	11.50	11.50	0.50	0.50
18	12	9.50	12.50	0.54	0.42
18	14	10.50	12.50	0.54	0.47
18	16	11.50	12.50	0.54	0.50
18	18	12.50	12.50	0.54	0.54
20	12	10.00	14.00	0.57	0.42
20	14	11.00	14.00	0.57	0.47
20	16	12.00	14.00	0.57	0.50
20	18	13.00	14.00	0.57	0.54
20	20	14.00	14.00	0.57	0.57

❖ visit pe.mcwane.com for more information

❖ All Dimensions are in Inches

TR FLEX® FITTING THICKNESS & DIMENSIONS TEES

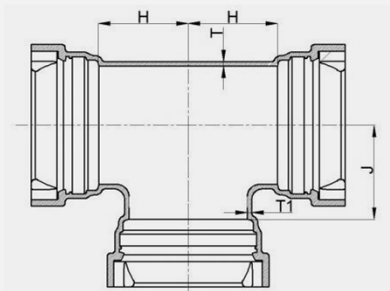

SIZE		H in	J in	T in	T1 in
Run	Branch				
24	12	10.00	16.00	0.61	0.42
24	14	11.00	16.00	0.61	0.47
24	16	12.00	16.00	0.61	0.50
24	18	13.00	16.00	0.61	0.54
24	20	14.00	16.00	0.61	0.57
24	24	16.00	16.00	0.61	0.61
30	14	12.50	20.00	0.66	0.47
30	16	12.50	20.00	0.66	0.50
30	18	15.00	20.00	0.66	0.54
30	20	15.00	20.00	0.66	0.57
30	24	16.00	20.00	0.66	0.61
30	30	20.00	20.00	0.66	0.66
36	14	16.00	23.50	0.74	0.47
36	16	16.00	23.50	0.74	0.50
36	18	16.00	23.50	0.74	0.54
36	20	16.00	23.50	0.74	0.57
36	24	16.00	23.50	0.74	0.61
36	30	20.00	23.50	0.74	0.66
36	36	23.50	23.50	0.74	0.74

❖ visit pe.mcwane.com for more information

❖ All Dimensions are in Inches



For Generations

TR FLEX[®] FITTING THICKNESS & DIMENSIONS CAPS & PLUGS

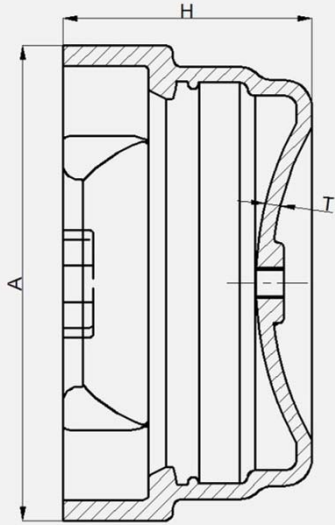

SIZE	A in	T in	H in
4	7.11	0.34	5.18
6	9.39	0.36	5.63
8	11.85	0.38	6.20
10	14.12	0.40	6.43
12	16.46	0.42	6.72
14	19.13	0.47	8.22
16	21.33	0.50	8.45
18	23.53	0.54	8.73
20	25.75	0.57	8.97
24	30.15	0.61	9.47
30	37.19	0.66	10.94
36	43.85	0.74	11.61

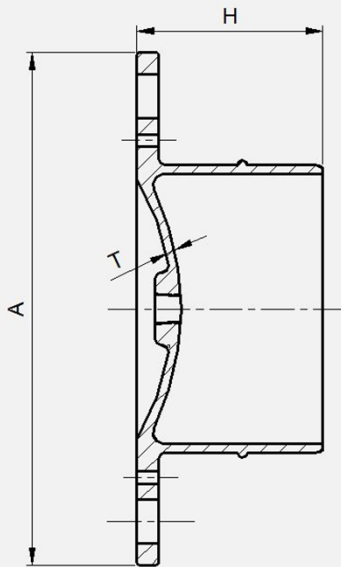

SIZE	A in	T in	H in
4	12.00	0.34	6.50
6	14.50	0.36	7.00
8	17.00	0.38	7.50
10	20.00	0.80	8.00
12	23.50	0.80	11.00
14	21.75	0.47	10.25
16	24.00	0.50	10.25
18	26.25	0.54	10.50
20	28.50	0.57	10.75
24	32.50	0.61	11.25
30	40.25	0.66	13.50
36	46.50	0.74	14.25

❖ visit pe.mcwane.com for more information

❖ All Dimensions are in Inches

**TR FLEX[®] RESTRAINED JOINT DUCTILE IRON
PIPE AND FITTINGS**



For Generations

4" - 36" DUCTILE IRON TR FLEX[®] PIPE ASSEMBLY INSTRUCTIONS

TR Flex[®] pipes and fittings assembly instructions:

- When laying a pipe or fitting in a trench, orient the locking segment insertion bell slots so that:
 - The 2 slots on 4" - 20" pipe are at the horizontal or 3 and 9 o'clock positions
 - The 4 slots on 24" - 36" pipe are at the 2, 4, 8 and 10 o'clock positions or forming an 'X' when looking at the bell face



4"-20"



24"-36"

- Thoroughly clean the bell cavity area including the gasket seat and the locking segment groove to remove all dirt, debris and any foreign material(s) that could inhibit proper gasket sealing or locking segment placement. Ensure the gasket seat area is dry
- Insert a standard Tyton gasket in the bell socket, make sure the retainer bead on the heel of the gasket is fully inserted into the corresponding socket groove
- Apply a thin but continuous layer of lubricant on the installed gasket and the pipe spigot up to the weld bead
- Keeping the mating pipe aligned, insert the pipe spigot into the corresponding pipe bell and push home
- There are two locking segments for 4" - 10" joints, four locking segments for 12" - 20" joints and eight locking segments for 24" - 36" joints
- Insert the locking segments one at a time into the bell slots and rotate / slide each locking segment into the bell cavity. Red segments rotate to the right and black segments rotate to the left
- Insert the rubber retainer into the bell slot between two installed locking segments to retain the locking segments in their correct position
- Once all locking segments and rubber retainers are properly installed, pull back on the installed joint to fully extend the joint and set any desired deflection

❖ visit pe.mcwane.com for more information

* TR FLEX[®] is a registered trademark of U.S. Pipe

**TR FLEX[®] RESTRAINED JOINT DUCTILE IRON
PIPE AND FITTINGS**